

An Alternate Compaction Grouting Technique

Alex Naudts¹, Rudy Van Impe²

Abstract:

This paper describes an alternate compaction grouting system. It also provides the theory and a mathematical model to assess and quantify the degree of soil improvement caused by compaction grouting. It further discusses a field application where this system has been successfully used.

The most common objective of compaction grouting is the densification of the soil whereby the grout does not permeate or fracture the soil matrix. This is typically accomplished by using low mobility grouts. Predictable results can also be obtained for some applications by utilizing the further described alternate method.

The alternate method involves the following:

Regular sleeve pipes (similar to those used in permeation grouting) are installed to the required depth, through the soil strata that need to be treated. Geotextile bags are strapped ("concertinad" on the sleeve pipe) straddling all or some of the sleeves. The geotextile bags are inflated via a double packer with a balanced, stable, low viscosity cement based suspension grout with high resistance against pressure filtration. Several bags (on different pipes) are inflated at the same time. The inflation process is done in stages to allow the water to slowly (pressure) filtrate through the geotextile bags. During each grouting stage the pressure is systematically increased. Because the compaction process is time related (with reference to Terzaghi's time settlement equations) the compressibility of these layers is gradually and systematically reduced. The spacing between the grout pipes has to be such that the soils are subjected to vertical stresses in excess of those they will eventually be subjected to. The volume reduction of the surrounding soils under the grouting pressure, as well as the influence radius of the compaction grouting can be mathematically estimated with the method described in this paper. This in turn dictates the spacing between the grout pipes.

By not attaching a geotextile bag on every sleeve, hydrofracturing or permeation grouting in conjunction with hydrofracturing can be conducted via these sleeves, after the compaction grouting has been completed.

1. Alex Naudts, M.A.Sc. Civ.Eng., P.Eng., ECO Grouting Specialists Inc., Amaranth, Ontario
2. Rudy Van Impe, Ph.D., Profession of structural Engineering, State University of Ghent, Belgium

A mid-rise condominium structure in Toronto suffered differential settlement as a result of the construction of an adjacent underground parkade. An array of sleeve pipes was installed in the loosened soils and the above mentioned process was implemented. All further settlement was arrested.

Methodology and Background

The goals of compaction grouting are either one or a combination of the following:

- to transfer loads to a virtually incompressible soil or rock horizon,
- to reduce the compressibility of soils to prevent or arrest settlement,
- to raise slabs and structures,
- to stop inflows of water through formations with large voids.

These goals are typically accomplished by injecting mortars and/or concrete with low slump (often referred to as low mobility grouts) under high pressure into the medium to be treated. Over the years more sophisticated approaches have been developed and a slightly better understanding of the engineering principles of the compaction grouting technique have been obtained. It should be noted however, that remarkable results and achievements have been reported with classic compaction grouting, especially in the field of lifting structures.

The main factors contributing to the success of compaction grouting are:

- understanding the technique and the equipment,
- understanding the structure,
- understanding the manner in which the surrounding soils react to the introduction of grout,
- understanding the rheology of the low mobility grout,
- understanding the cause of the problem and the geotechnical aspects of it.

Most of the goals of classic compaction grouting however can be elegantly accomplished with regular cement based suspension grout. The key is to control the travel (the containment) of the grout and prevent hydrofracturing of the medium. In applications where the densification of the soil is the main issue, a classic, low mobility grout can be replaced by the alternative compaction grouting technique as further described.

The alternative technique involves the injection of a regular cement based suspension grout into a geotextile form. The geotextile is installed concentrically onto a sleeve pipe or mounted onto the end of a standpipe. The geotextile is pleated (much like the baffles of an accordion) to reduce it to a sufficiently small size to fit inside the casing without damaging the bag as the pipe is inserted. The

geotextile prevents the grout from fracturing the soils but allows the water to filter out of the bag. The grouting pressure is transferred to the surrounding soils, inducing additional radial and vertical stresses, in turn creating additional compaction of the soils a distance away from the grout columns.

An appropriately formulated cement based suspension grout must be selected for the alternate compaction process. It must have a low pressure filtration coefficient, K_{pf} , ($K_{pf} < 50 \times 10^{-3} \text{ min}^{-0.5}$ (API, 1988)) and delayed set for the grouting pressure in the geotextile bag to be exerted and maintained for a long time before the pressure filtration process is complete. The geotextile acts as a flexible form and a filter membrane, allowing the water to be squeezed from the grout, retaining the solids within the bag. This is an alternate approach to produce a grout that won't permeate or fracture the soils.

During the inflation of the bags in situ, the geotextile acts as a pervious membrane which prevents fracture of the soil medium from migration of pressurized grout. Inflation of the bags, from their initial collapsed state, is conducted in stages. The grouting pressure at any one time during grouting is equivalent to the additional radial stress, σ_r , at the bag-soil interface. The additional radial stress decreases with increased distance away from the limits of the geotextile bag. As inflation proceeds and the area of bag in contact with the surrounding soil increases, additional radial and vertical stresses are induced in the surrounding soils, in turn creating additional compaction of the soils a distance away from the grout columns.

The compression of soils, which is the goal of many compaction grouting operations, is directly related to the additional stresses induced by the compaction grouting. The compression of the soils is also a time-related matter. The longer the pressure is exerted the more pore water gets squeezed out of the soil matrix and the denser the soil becomes. By subjecting soils for a sufficiently long time to stresses higher than those they will eventually be exposed to, the ultimate settlement under these circumstances are vastly reduced.

Mathematical Model

The calculation of the stress distribution caused by compaction grouting around and a distance away from a "compaction grout cylinder" is a rather complicated matter. The soil is not homogeneous and is an aleotrope medium. Strictly speaking, the soil is not a continuum but a discontinuum.

A finite element study could be the most accurate mathematical system to reliably compute the aforementioned stress distribution. This finite element study however is only meaningful if and only if, the numbers entered in the mathematical model truly reflect the soil characteristics. The latter are typically oversimplified, making the finite element study often rather meaningless.

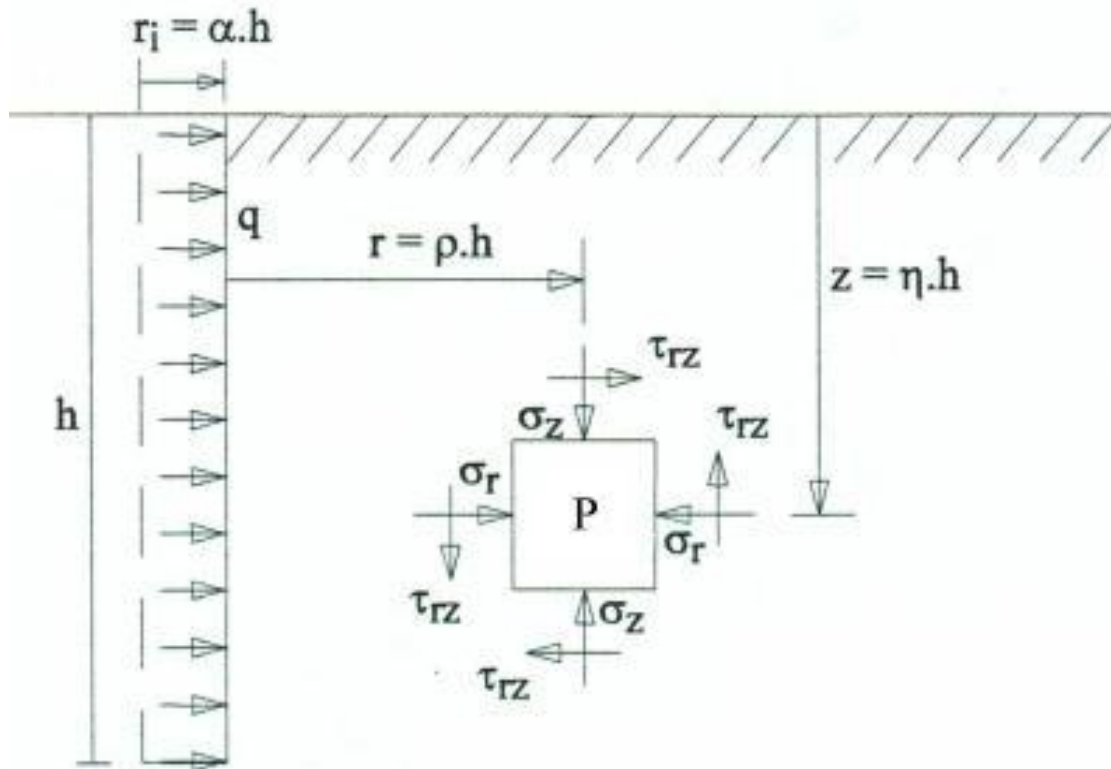

Figure 1

For this reason the following theory expressed in this paper has been developed to provide a mathematical model for the calculation of the stress distribution caused by this type of compaction grouting. The following assumptions have been made:

1. Axial symmetry: Even if the soil characteristics around the compaction column are axially symmetric, it remains an approximation because typically more than one column contributes to the stress on a soil cube a distance, r , away from the grout cylinder but within the direct influence of a given grout column.
2. The stresses σ_r , σ_z , τ_{rz} exerted on a cube surrounding a point P, a horizontal distance r away from the compaction grout cylinder, triggered by a pressure q within the geotextile bag can be estimated in accordance to Boussinesq's Theory (DeBeer, 1970). The point P, is located a depth z , below the surface; $z = \eta h$. Dimensionless coordinates ρ and η are introduced by expressing the horizontal distance $r = \rho h$ and the depth $z = \eta h$ in terms of the height of the grout cylinder (figure 1).

The authors utilize a simple, straightforward mathematical model and selected Boussinesq's theory for a plane strain situation (figure 2).

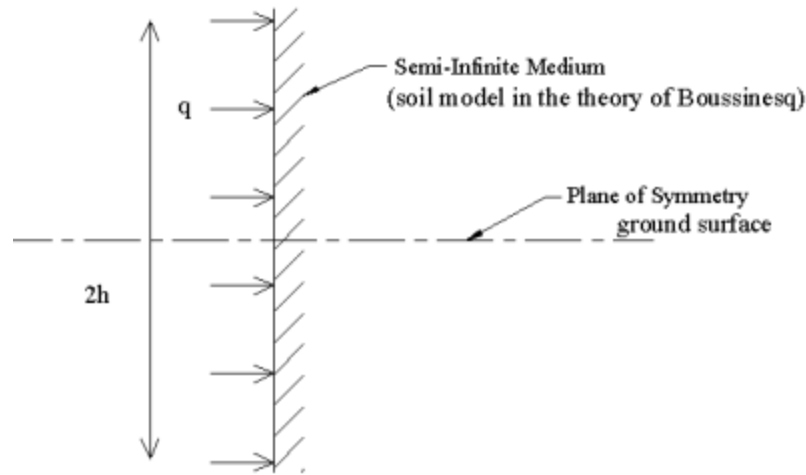

Figure 2

Under the two aforementioned assumptions, the additional stresses in P a distance r away from an actual grout column with height h , caused by a uniform grouting pressure q , exerted within a hypothetical grout column with a height of $2h$ can be determined. (h being the actual depth of the grout cylinder below surface; a mere fictitious distance h above the surface is added: this way the shear stress at surface level is zero along the entire ground surface). A shortcoming of this theory of course is the fact that the normal stresses, σ_z , are not zero at the actual surface level.

The stresses in P induced by compaction grouting in one column are therefore given by:

$$\sigma_r = \frac{q}{\pi} \left[\alpha \tan \frac{1-\eta}{\rho} + \alpha \tan \frac{1+\eta}{\rho} + \frac{(1-\eta)\rho}{(1-\eta)^2 + \rho^2} + \frac{\rho(1+\eta)}{\rho^2 + (1+\eta)^2} \right]$$

$$\tau_{rz} = \frac{q}{\pi} \left[\frac{(1-\eta)^2}{(1-\eta)^2 + \rho^2} - \frac{(1+\eta)^2}{\rho^2 + (1+\eta)^2} \right]$$

$$\sigma_z = \left[\alpha \tan \frac{1-\eta}{\rho} + \alpha \tan \frac{1+\eta}{\rho} - \frac{(1-\eta)\rho}{(1-\eta)^2 + \rho^2} - \frac{\rho(1+\eta)}{\rho^2 + (1+\eta)^2} \right]$$

According to Boussinesq's Theory, the section on which the pressure q is exerted has a thickness equal to 1 in the plane perpendicular to the drawing in figure 1. As a result, a correction factor must be introduced to reflect the effect of dissipation in radial stresses at a depth z :

- for $r = r_i$: q is actually only exerted along a circle with circumference $2\pi r_i$,
- for $r = r$: the available circumference has increased to $2\pi (r+r_i)$,
- Therefore the stresses as expressed in equations 1 to 3 must be multiplied by a factor β .

$$\beta = \frac{r_i}{r + r_i} = \frac{\alpha h}{\rho h + \alpha h} = \frac{\alpha}{\rho + \alpha}$$

(refer to figure 1 for meaning of symbols)

The correction factor β has been introduced to maintain the static equilibrium in a radial direction. Plan view of a section of soil within the influence zone of the grout column with an internal angle of $d\theta$ is shown in figure 3. In figure 3, R_1 is the resultant of q exerted along $r_i d\theta$. Therefore, $R_1 = q r_i d\theta$. R_2 is the resultant of σ_r exerted along $(r+r_i)d\theta$. Therefore, $R_2 = \sigma_r (r+r_i)d\theta$. Equilibrium requires that $R_1 = R_2$, hence $\sigma_r = q r_i / (r+r_i)$. This in turn, is the rationalization behind the correction factor β

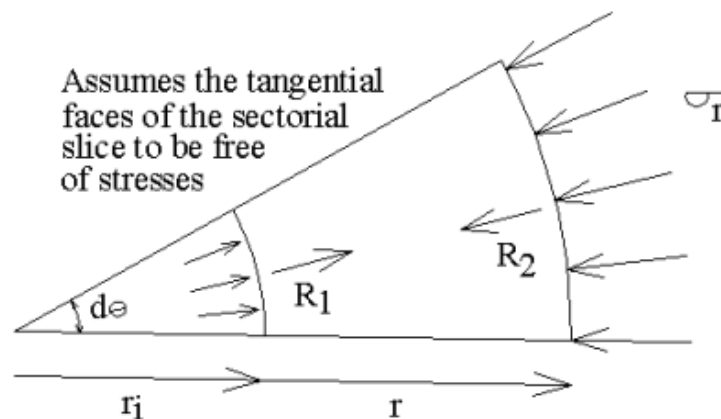

Figure 3

Effect of Stress Situation in P Resulting from Compaction Grouting in Several Columns:

The effect of compaction grouting via several grout columns is taken into account to compute the stresses on a cube surrounding P. This is done as follows (simplified model):

The assumption is that there are n grout columns in a square of which the length of the side equals b (column spacing). The amount of compressed soil as a result

of the compaction grouting in n columns equals $n \cdot \pi r_i^2$. The increase χ , in density of the soils, with original density γ , is given by:

$$\chi = \frac{1}{1 - n \frac{\pi_i^2}{b^2}}$$

Conclusion: Based on the aforementioned, the stresses on a soil cube surrounding, P, are given by equations 6-8:

$$\sigma_r = \frac{\rho A}{\pi} \left[\alpha \tan \frac{1-\eta}{\rho} + \alpha \tan \frac{1+\eta}{\rho} + \frac{(1-\eta)\rho}{(1-\eta)^2 + \rho^2} + \frac{\alpha(1+\eta)}{\rho^2 + (1+\eta)^2} \right] + \lambda_n \chi \gamma h$$

$$\sigma_z = \frac{\rho A}{\pi} \left[\alpha \tan \frac{1-\eta}{\rho} + \alpha \tan \frac{1+\eta}{\rho} - \frac{(1-\eta)\rho}{(1-\eta)^2 + \rho^2} - \frac{\alpha(1+\eta)}{\rho^2 + (1+\eta)^2} \right] + \chi \gamma h$$

$$\tau_{rz} = \frac{\rho A}{\pi} \left[\frac{(1-\eta)^2}{(1-\eta)^2 + \rho^2} - \frac{(1+\eta)^2}{\rho^2 + (1+\eta)^2} \right]$$

in which λ_n is the "neutral" soil coefficient (coefficient of earth pressure at rest); γ the specific gravity of the soil and symbols β and χ are defined by equations 4 and 5 respectively. The second term in equations 6 and 8 takes into account the effect of the ground squeezing. The first term takes into account the attenuation according to Boussinesq's Theory.

If the density of a medium increases with a factor χ , it will have an effect on the vertical stresses (as well as the horizontal soil stresses but not really on the shear stresses) in the soil and because of the neutral soil coefficient, λ_n .

The graphical representation of the radial normal stresses and shear stresses, given by equations 1 and 2 respectively, are depicted in figures 4 and 5. Note that these graphs do not take into account the correction factors which are introduced in equations 6-8. If the range of ρ is increased on the graphs, the stress curves approach zero.

Radial Stress

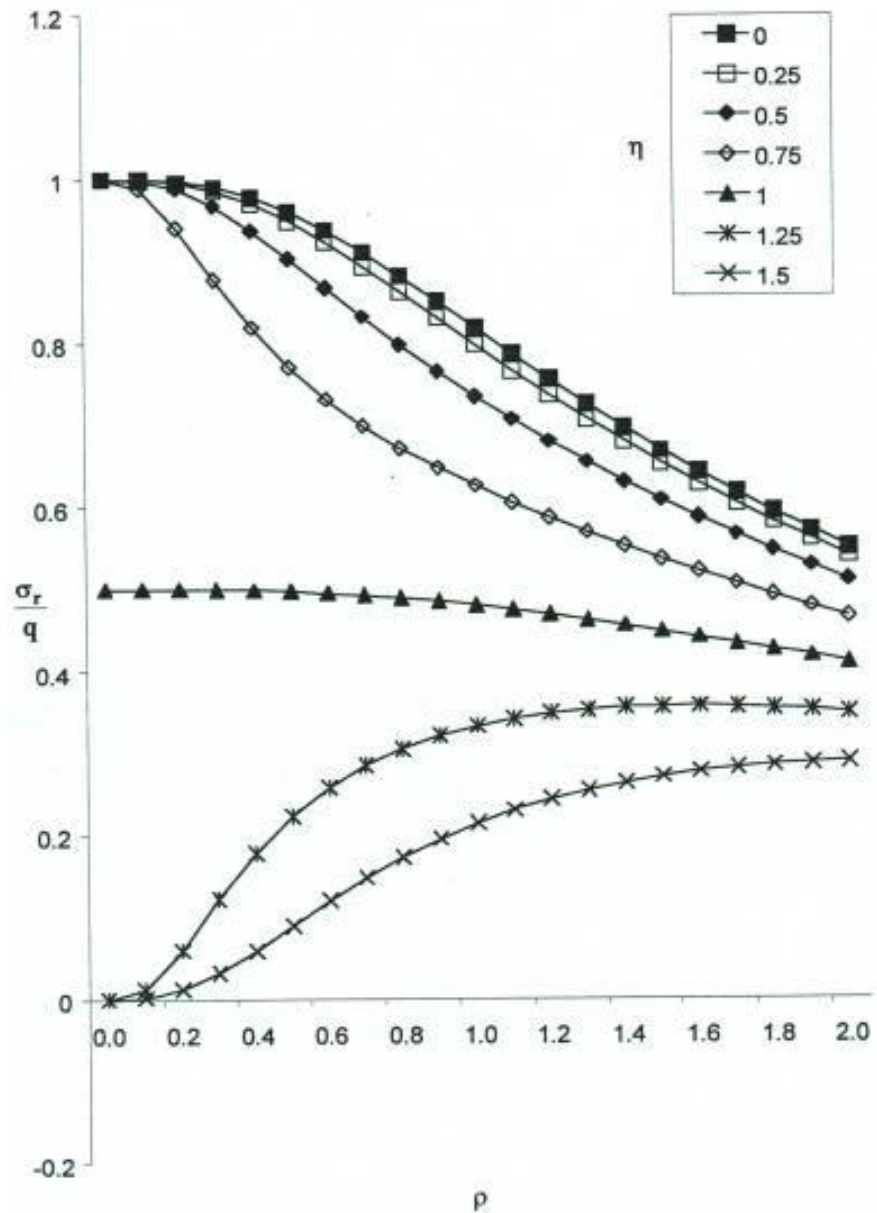

Figure 4: The value of σ_r/q as calculated with equation 1.

Please note that the actual value of σ_r is obtained by multiplying the depicted one with the correction factor β .

Shear Stress

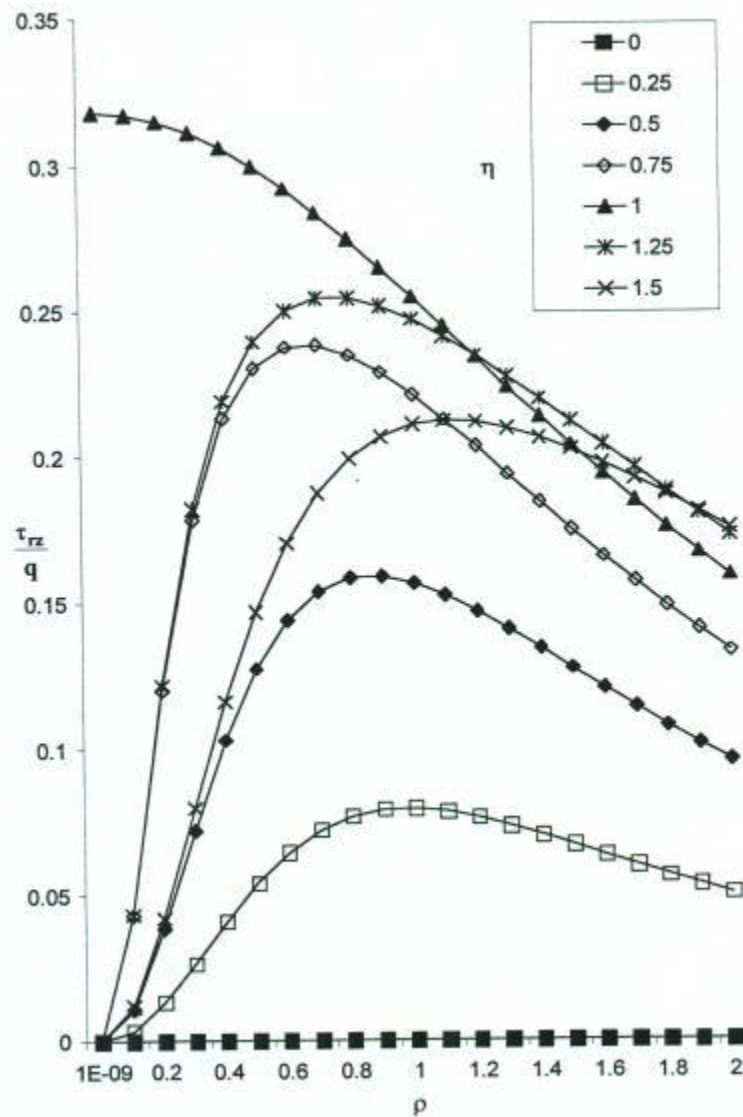

Figure 5: The value of τ_{rz} as calculated from equation 2.

Please note that the actual value of τ_{rz} is obtained by multiplying the depicted one with the correction factor β .

It is not practical/feasible to continue to exert pressure for extended periods of time on a classic low mobility grout. This considerably limits the impact or soil improvement of classic compaction grouting. Moreover, because of the high internal friction within the classic low mobility grout, the pressure dissipates quickly from the injection point to the fringes of the low mobility grout bulb. In the alternate approach it is possible to maintain the grouting pressure for more than 2 hours in each grout column provided properly formulated low viscosity cement

based suspension grouts contained by geotextile bags are used. This enables densification of soil, especially if the soil is not saturated or if dissipation of the pore water pressure can be accomplished in this time frame.

The ultimate reduction in volume caused by the increased stresses can be estimated with Terzaghi's equation. At a depth z , the radial compaction Δ_s is:

$$\Delta_s = \int_{r_i}^{r_{ok}} \frac{r}{C} \ln \frac{P_0 + \sigma_r}{\rho} dr$$

$$C = \frac{3}{2} \frac{C_{kd}}{P_0}$$

with

(C_{kd} is the cone penetration value at depth z , obtained via the Dutch cone penetrometer test)

P_0 = original vertical stress in P (i.e. the stress caused by the weight of the soil).

C = Terzaghi's compressibility coefficient.

The average value of Δ_s can also be estimated by recording the volume of grout placed in adjacent columns during compaction grouting. It is recommended to graphically determine Δ_s (Naudts, 1995). The amount of soil improvement is reflected by the increase in the value of C .

Comparison with "Classic" Compaction Grouting

In the alternate grouting approach, several geotextile bags are "inflated" with low viscosity cement based suspension grout at the same time. The grouting parameters (pressure, flow, accumulated flow) of this process are recorded individually (bag per bag) in real time. The grouting pressure is systematically increased in stages during which the pressure filtration is causing further built-up of the filter cake. The pressure is transferred from the geotextile bag on to the surrounding soils. Under the additional vertical and radial stresses the soil is compressed. The amount of compression the soil within the influence radius of the grout hole will undergo is governed by the compressibility coefficients C , of the soil layers and the additional stresses caused by the compaction grouting (equations 5 -8).

Classic compaction grouting consists of pumping a low mobility grout at high pressures, at discrete locations to densify soft, loose or disturbed soil. It may not be practical/feasible to exert pressure on these low mobility grouts/concretes for

extended periods of time. As a result, the effect of compaction grouting is localized. The alternative technique can treat more soil volume in a more predictable and repeatable fashion with fewer grout holes to obtain the same or higher degree of soil improvement.

The following advantages of the alternate compaction grouting technique over the classic compaction grouting method should be recognized (provided the geotextile bags are of adequate quality, secured properly and injected with a stable, retarded, low viscosity cement based suspension grout with low pressure filtration coefficient):

- grouting pressure can be maintained at relatively high levels for extended periods of time allowing pressure filtration to occur within the grout, increase compression of the soil and allow more time to squeeze out pore water from the soil matrix in saturated soils,
- the mathematical model provided above can be used to calculate/estimate the hole spacing required to achieve the desired soil improvement,
- provides greater control and reduces the risk of hydrofracturing. The system provides more controlled ground heave which could potentially damage near by structures,
- any number of sleeves can be used for compaction grouting, leaving the remaining sleeves for additional soil improvement via permeation grouting (in conjunction with hydrofracturing),
- can be executed with small "classic" grouting equipment.

For projects in which the densification of the soils is the main issue, the alternate compaction grouting technique can result in a controlled, predictable and efficient compaction grouting program. It needs to be pointed out that the geotextile bag system has been used by Heenan and Naudts since 1992 (Naudts, 1995) for the construction of mini piles and anchors. The increase in lateral bearing capacity (compared to a pressure grouted soil anchor) is substantial (a factor of 5-20 depending on soil characteristics, grouting pressure, placed volume of grout) even when placed below the water table in saturated soils.

This alternate technique can also be used to lift structures. The flexible form has to be adjusted in shape and size. Multiple hole grouting is necessary to evenly lift the structure. Multiple hole grouting is difficult in classic compaction grouting and requires several grouting units.

Compaction grouting is also used to control leaks through cavities. In most cases this can also be done by inflating large bags with cement based suspension grouts. The "open" sleeves in turn can be used for hot bitumen grouting which still is the most efficient grout to deal with major inflows. In 1996 a leak of 7 cubic meters per second driven by a 150-psi pressure gradient was successfully cut off

in the Philippines. In this application, the geotextile bags were inflated independently from the bitumen delivery pipes.

Recent evolution in hot bitumen grouting, as developed on a project in West Virginia, demonstrated that it is possible to inject cement based suspension grouts and hot bitumen at the same time in the same sleeve pipe system.

Case Study of the Alternate Compaction Grouting Technique

A 65-year old mid-rise structure (hospital) located in Toronto Canada was damaged as a result of settlement of one corner of its foundation. The settlement occurred after the soil below its footing was loosened during construction of a drilled caisson wall immediately adjacent the structure. A controlled, predictable technique was required to remediate the loose soil condition without further damaging the structure. Permeation grouting in conjunction with the alternate compaction grouting technique was employed.

The southwest foundation perimeter (approx. 25 lineal metres) of the structure borders very closely (0.6m) to the caisson wall foundation at the new development. The caisson walls were installed to depths in excess of 2m below the existing strip footing of the damaged structure. The installation process of the caisson walls in the vicinity of the southwest corner caused disturbance and soil loss beneath the existing footings. This resulted in a considerable increase to the compressibility of the founding soils. After undergoing substantial initial differential settlement, the structure continued to slowly settle because of the loose founding soil condition below part of the structure. It was feared that fluctuation of the water table or seismic loading could result in unacceptable further differential settlement and put the entire structure in jeopardy.

Design Considerations:

The owner approached the authors looking for a design-build turnkey solution. The authors were provided with the results of previous geotechnical and forensic investigation, most notably the sieve curves of the founding soil and standard penetration test results from a series of bore holes advanced through the disturbed zone. Based on this information, it appeared that the d_{10} of the soil varied between 0.01 mm and 0.1 mm. The theoretical in situ permeability coefficient, k , was calculated based on Hazen's equation and based on extrapolated sieve data was between 1.0×10^{-2} and 1.0×10^{-4} cm/sec. Hazen's equation is generally accurate for dense soils (N between 25 and 40). Since the encountered soils were disturbed, it should be expected that the actual in situ permeability coefficients are much higher than the calculated values with Hazen's equation. These soils therefore, were likely injectable through permeation grouting with microfine cement based suspension grouts. The following design considerations were also taken into account:

- It was the express wish of the owner not to jack any of the settled footings back to original elevation.
- Only the disturbed zones required treatment.
- The use of circulated fluids or percussive energy drilling techniques could further exacerbate the settlement of the settled footings (additional soil loss).
- Access to the work could only be obtained from the basement storage room of the damaged structure, negating the use of any heavy equipment that could not be passed down a narrow staircase and through a man door.
- The soil in the target zones varied from medium-fine sands to medium silts, eliminating the possibility of performing permeation grouting alone.
- The excessive pressures required for classic compaction grouting and the imperfect monitoring/control style of conventional compaction grouting techniques was undesirable.
- The improvement had to be quantifiable.

Design Approach

A significant amount of time had elapsed between remediation and the initial disturbance caused by the caisson installation. This resulted in a fragile equilibrium being reached between the structure, the foundation system and the disturbed founding soil in one zone of the building. In order not to further disturb this fragile equilibrium, the following remediation approach was conceived.

- A proprietary hydraulic system was developed to allow installation of cased bore holes without further disturbance of the already loosened soil.
- Sleeve pipes outfitted with geotextile bags on every other sleeve (50% of the sleeves in the disturbed zone) were installed. This left 50% of the sleeves available for permeation grouting.
- Installation of sleeve pipes took place in 2 distinct stages to avoid having installed all pipes before any beneficial treatment of the soil could be achieved.
- A suite of deflection and movement monitoring instrumentation was installed on the structure and monitored at all times to detect any movement (settlement or jacking) of the foundation during pipe installation and grouting.
- Sleeves encompassed by barrier bags were compaction grouted prior to a 3 stage permeation (in conjunction with hydrofracturing) grouting program.

Execution

The grouting operation consisted of the installation of 15 sleeve pipes. All primary sleeve pipes were inserted into casings jacked into place on approximately 2.4m centres from within the basement of the damaged structure. The secondary

(verification and grout) pipes were later installed at midpoint. Sleeve pipes were installed under a 65° angle (from horizontal) over a 9.7 m length with over 4 m to be used for permeation and compaction grouting. A geotextile bag straddled every other sleeve for use during the alternate compaction grouting operation. All odd numbered sleeve pipes were subjected to compaction grouting with a stable regular cement based grout prior to compaction grouting in the even numbered sleeve pipes. Only 50% of the sleeves were used in this process. Permeation grouting was performed in the remainder (50%) of the sleeves after all compaction grouting in the primary holes was complete. Typically, each sleeve was grouted 3 times (once with microfine cement based suspension grout and two pass with sodium silicate solution grout). Any sleeves which did not refuse (less than 1 l/min for 5 minutes) after 3 passes were injected with regular cement based suspension grout to absolute refusal. Due to variations in the soil disturbance, some barrier bags broke (too much room for the bags to expand) in the primary holes. Some barrier bags did not take much grout at all (soil tightened during the compaction grouting of the primary holes). Any barrier bags, which broke during the compaction grouting, were used for permeation grouting to ensure proper ground treatment. The barrier bags had the ability to inflate to a diameter of 45 cm (18") before they ruptured. Figure 4 illustrates a typical sleeve pipe arrangement used for both compaction grouting and permeation grouting.

Compaction grouting was performed using a stable cement based suspension grout containing water, cement, bentonite, fly ash, whelan gum, super plasticizer and retarder. A total of 37 bags were properly inflated and 3788 l of grout was injected. Geotextile bags brought to proper refusal as indicated below, typically took between 50 and 130 litres of grout. Compaction grouting of each barrier bag was performed in stages. Grout was injected into the barrier bag via the sleeve it encompassed. The grouting operation was performed in stages. Stage 1: effective pressure was taken to 25 psi and held for 5 minutes, stage 2: pressure was increased to 35 psi and held for 5 minutes, stage 3: pressure to 45 psi, stage 4: 100 psi and stage 5: 200 psi and held for 5 minutes at each stage. In this manner, the pressure was gradually applied to the surrounding formation, densifying the soil while a filter cake was building inside the bag. The dissipation of pore water pressure was not an issue, since the water table was below the zone to be treated.

Prior to permeation grouting, in-situ hydraulic conductivity tests were performed via a distinctive number of sleeves. In the primary holes, the calculated permeability values (equation Caron) still indicated values slightly greater than the ones calculated using Hazen's equations. In the secondary holes the in-situ values were already very similar to the theoretically calculated ones.

Permeation grouting in the primary holes was performed after completion of compaction grouting in the primary holes. The sleeves not used for compaction grouting (50%) and any sleeves where geotextile bags broke were used in the

permeation grouting program. Typically, the first grouting pass was made with microfine cement based suspension grout. Passes 2 and 3 were performed with sodium silicate solution grout and the total volume of sodium silicate exceeded the theoretical volume. Any sleeves that had not refused after a second pass with sodium silicate were injected with regular cement based suspension grout to refusal. The amount of "refusal" grout injected equaled 6% of the theoretical volume. The theoretical volumes are based on average grout spread of 60 cm and accessible pore volume of 30%. The grout spread had been calculated with the equation of Cambefort-Naudts. All operations were monitored in real time with CAGES™. CAGES also provides calculation of the grout spread in real time. Several holes were grouted at the same time and individually monitored via CAGES.

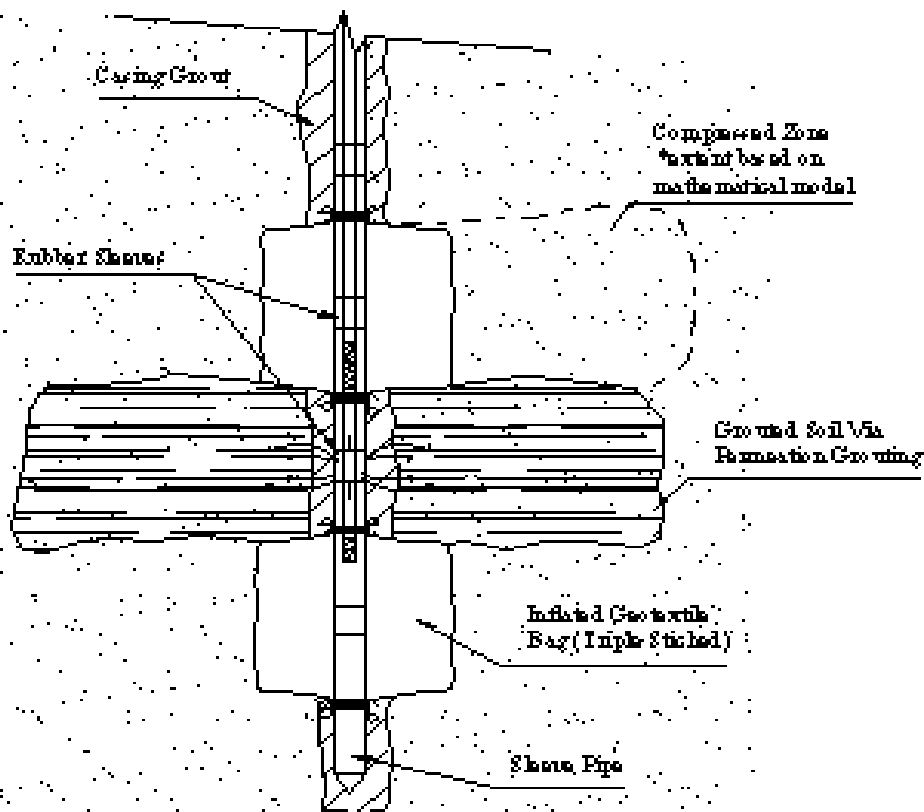

Steps:

1. Inflate Barrier Bags Systematically Increasing pressure
2. Inject a Suitable Grout Through Other Sleeves for Permeation

Figure 6

After the grouting of the primary holes was completed, the secondary holes were grouted. A significant densification of the soil became obvious. The compaction grouting operation via the sleeves on the secondary holes indicated considerably denser soils. The injected volumes were consistently lower than via the sleeves of the primary holes.

The grout takes via the sleeves for permeation grouting were lower than the ones on the primary holes, but not significantly. The latter can be explained as follows: the sleeves for permeation grouting were both located in soils that had already been densified by compaction grouting.

The use of an alternate compaction grouting technique in conjunction with permeation grouting proved successful for this project. The disturbed soil zone was densified by systematically inflating geotextile barrier bags. The use of geotextile bags made it possible to apply high pressures for extended periods of time. Compaction grouting with barrier bags is an efficient method of densifying the soil prior to permeation grouting. The increased densification of the surrounding soil allows the permeation grouting time and grout quantity to be greatly reduced (obviously inflating a barrier bag can be performed in a much shorter time than that required to permeate the same effective area, in disturbed or loose soil conditions).

Summary

The alternate compaction grouting technique described in this paper has some advantages over the "classic" method of performing compaction grouting, particularly when densification of the soil is the main issue. The alternate compaction grouting technique is a more controlled and predictable technique for densifying soil. A mathematical model can be developed to determine the effects of this compaction grouting program and thus the hole spacing and depth of treatment can be determined to meet the project goals. The use of sleeve pipes with geotextile bags placed on every other sleeve allows for permeation grouting to take place to compliment the compaction grouting program. To enable high pressures to be applied to the formation in stages and thus compact the soil over a substantial distance from the grout cylinder it is necessary to:

- use a well formulated low viscosity cement based suspension grout with high resistance to pressure filtration,
- use appropriate triple stitched geotextile bags properly secured to the sleeve pipes,
- perform a properly monitored compaction grouting program.

The danger of hydrofracturing the soil and causing further damage to the existing structures is greatly reduced if proper monitoring is performed. By leaving a number of sleeves accessible for permeation grouting, the compaction grouting is

further enhanced via a permeation/hydrofracturing grouting operation. A predictable and quantifiable ground treatment is achieved with this technology.

The alternate compaction grouting technique employed at a site in Toronto, Canada demonstrated the capabilities of such a technique in difficult conditions.

Acknowledgment: The Authors wish to thank Mr. Jim Bruce, P. Eng. with Underground Services Ltd. for providing assistance, data and information with respect to the case study presented in this paper.

References

1. American Petroleum Institute (API). (1988). Standard procedure for testing drilling fluids. API RP 13, Washington, D.C.
2. De Beer, E.E. (1970). Volume 2 of "Grondmechanica", Standard Scientific Publishers.
3. Naudts, A. (1995). Chapter 5B of "Practical Foundation Engineering Handbook", Editor - Brown, R.W., McGraw-Hill, New York, 1995, ISBN 0-07-008194-8, pp. 5.284-5.289, 5.309, 5.297-5.298, 5.311-5.312.